

## Single Sided Indoor Merchandising Systems

### BENEFITS

Cost Effective & High Quality illuminated Merchandising display systems in standard or custom-made designs, size, and colours. Designed to ensure ease of operation and maintenance. Other benefits include:

- Very low maintenance with rapid fluorescent tube access
- Easy and fast translite change with hinged magnetic trim
- Effective and safe translite retention
- Includes a new curved face design
- Designed specifically to exclude loose parts

### SPECIFICATIONS

The Coates Signco Rollerboard™ Single Sided in one size only:

- Single Module - 715mm in height, accommodating one single translite.
- Bright backlit illumination.
- Custom size available.

The Rollerboard™ units are electrically wired for 220v - 240v, 50Hz as standard. 110v wiring and or special electrical requirements are also available.

### TRANSLITE SIZES

For best result we recommend satin finish translites to be used.

The Coates Signco Rollerboard™ accommodates translite size:

- Single: 630 x 700mm allow + 1mm-3mm tolerance

Preferred translite thickness is 0.3mm (0.0188")

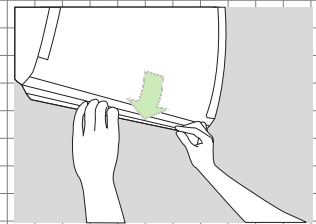

Ease open magnetic trim at bottom edge of unit

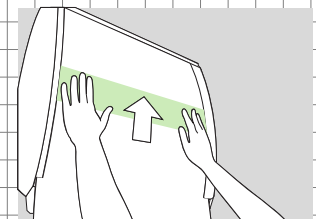

Gently push translite into place and under top trim

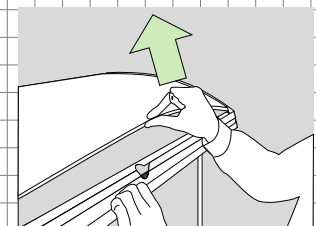

Simple fluorescent tube access

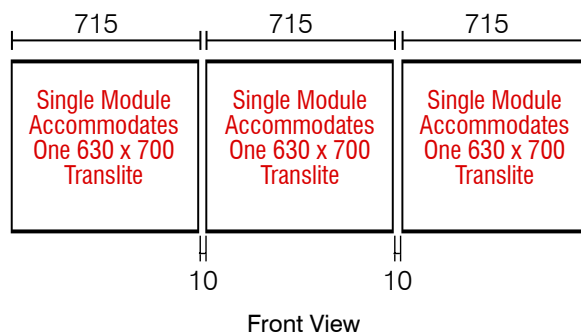
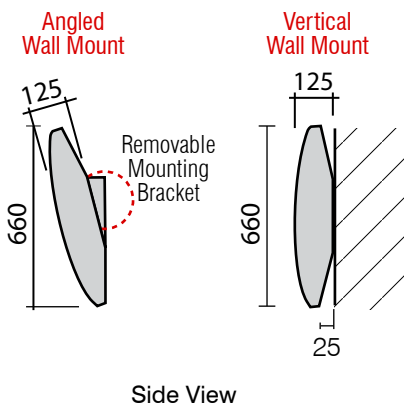

Coates Signco Pty Ltd  
242 Young St Waterloo  
NSW 2017 Australia  
T +61 2 9699 3122  
F +61 2 9698 2379  
www.coatessignco.com  
sales@coatessignco.com.au

For Custom Design Merchandising Systems, please call (02) 9699 3122  
Visit our showroom to see our extensive range of Merchandising Systems.